



karmetalusa

Merge of art and craft



www.karmetal.us



karmetal
Merge of art and craft

Karmetal was founded in 1975 for manufacturing special purpose machines. During 1980's, Karmetal started to manufacture spare parts for automotive factories and Turkish military. In 1997 we manufactured our first band saw machine. It was additional to spare parts production. In 2002 Karmetal quit spare parts production and focused merely on band saw machines production. We rapidly increased our model quantity and now we are the leading band saw machine manufacturer in Turkey. Quality of Karmetal has been approved with TÜV-SUDVEST DIN EN ISO 9001:2008 and TURQUM quality certificates and our machines are compatible with the CE standards. We provide 2 years warranty for mechanics and 1 year warranty for electric-electronic parts with this convenience.

Karmetal serves domestic and international market with great reputation and improving its recognition all around the world day by day. We export our machines more than 40 countries including USA,UK, Germany, Australia and Russia. Karmetal has a very strong sales net.

KARMETAL regards its quality policy as ; to be competitive in prices with high quality products and after sales customer satisfaction with following the technologic developments, targeting to be a World brand with a prosperous and extending organization.

Karmetal has increased its production volume by modernizing its machinery inventory. Karmetal aims to present new products developed by Research and Development department and penetrate in the market .



Karmetal USA is Karmetal's own company representing Karmetal in the USA. Karmetal is a rapidly increasing its reputation all around the world and it led us to found our own company in the USA. Karmetal is being represented in the USA since 2007. USA market has a very important position in Karmetal's future plans. Due to importance of the market Karmetal USA is founded.

The role of Karmetal USA is to represent Karmetal in the USA, distribute machines, make connections, arrange and audit after sales services and provide excellent customer satisfaction. Karmetal USA lets us to establish closer connections with US customers and react faster to their requests.

KMT 700 KDG

SEMI-AUTO MITER DOUBLE



Sensitive Pressure - Inverter - Hydraulic Brake



Material Infeed Table



Motorized Chip Brush



Chip Conveyor



Hydraulic Top Clamp

COLUMN BAND SAW MACHINE

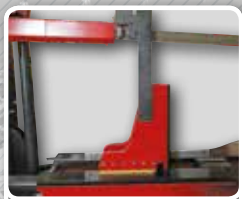
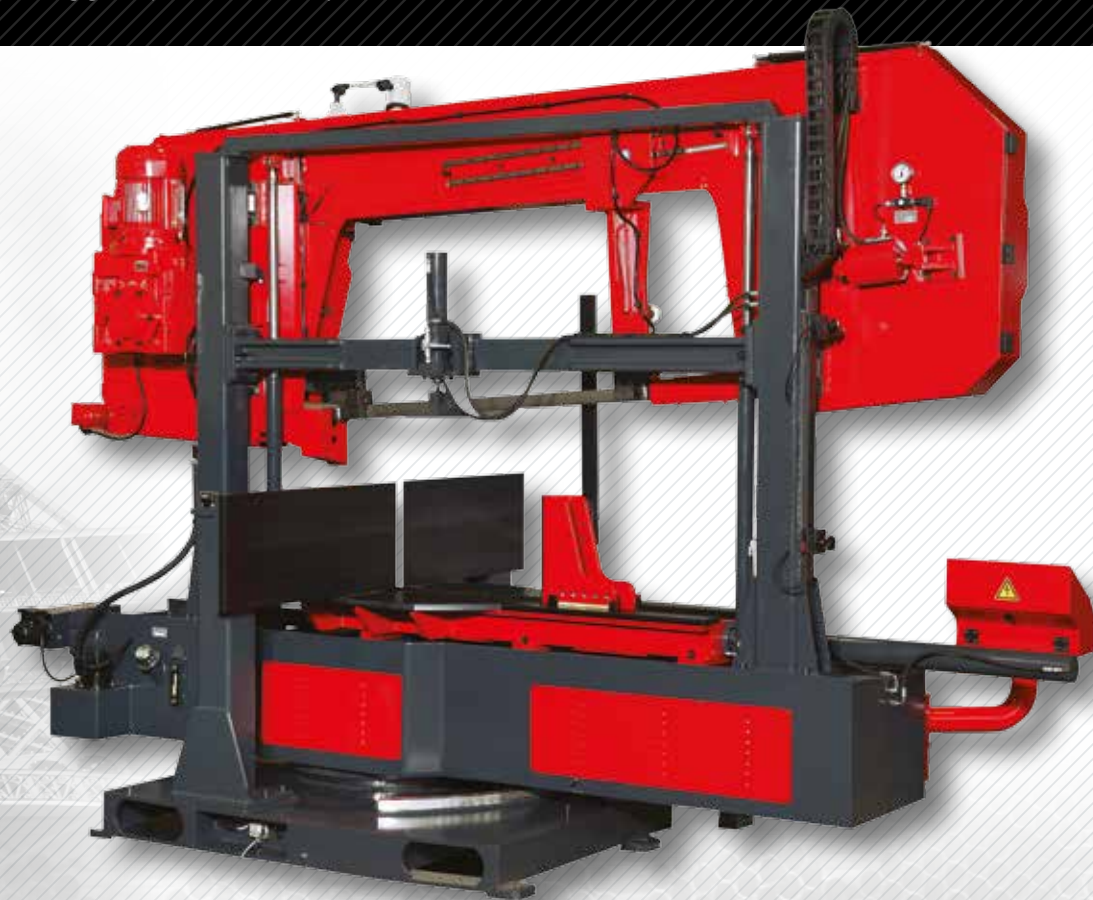

Hydraulic Vise



Hydraulic Band Tension

CUTTING CAPACITY

	0°	30°	45°	60°	-30°	-45°
	27.5"	27.5"	27.5"	18.9"	27.5"	27.5"
	27.5"	27.5"	27.5"	18.9"	27.5"	27.5"
	27.5" x 49.2"	27.5" x 42.1"	27.5" x 33.6"	27.5" x 23"	27.5" x 40.9"	27.5" x 32"

TECHNICAL SPECIFICATIONS

Main Motor	Hydraulic Motor	Conveyor Motor	Coolant Motor	Cutting Speed	Blade Size	Weight	Working Height	Dimensions
10 HP	2 HP	3/16 HP	1/4 HP	49 - 246 fpm	27' 11 3/8" x 2" x 0.06"	12125 lbs	34.2"	71" x 110" x 173"

KMT 560 KDG

SEMI-AUTO MITER DOUBLE



TECHNICAL SPECIFICATIONS

Main Motor	Hydraulic Motor	Conveyor Motor	Coolant Motor	Cutting Speed	Blade Size	Weight	Working Height	Dimensions
7.5 HP	2 HP	3/16 HP	1/4 HP	59 - 246 fpm	23' 5 ⁵ / ₁₆ " x 2" x 0.06"	7716 lbs	34.45"	78.7" x 137.8" x 88.6"

COLUMN BAND SAW MACHINE

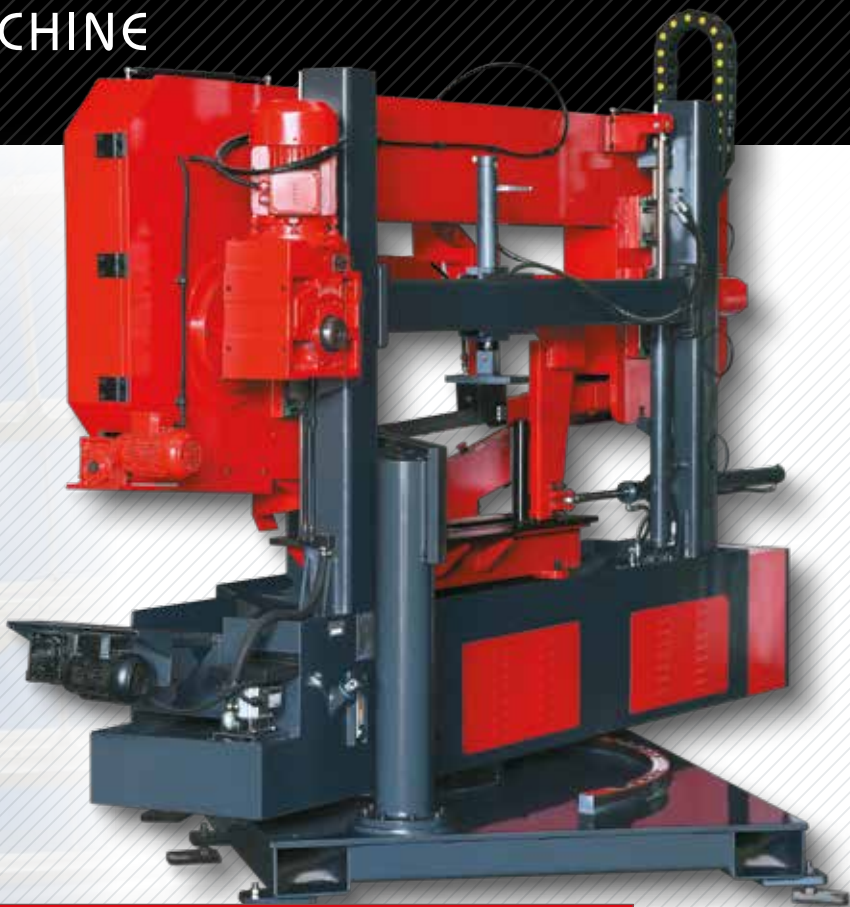

Sensitive Pressure - Inverter - Hydraulic Brake

CUTTING CAPACITY

	0°	30°	45°	60°	-30°	-45°
	22"	22"	19.6"	17.7"	22"	19.7"
	22"	22"	19.6"	17.7"	22"	19.7"
	21.25" x 41.3"	21.25" x 33.4"	21.25" x 26.75"	17.7" x 18.1"	21.25" x 37"	21.25" x 31.5"



Linear Guided Guide - Vise



Hydraulic Band Tension



Material Infeed Table



Motorized Chip Brush



Chip Conveyor



Hydraulic Top Clamp

KMT 400 KDG SEMI-AUTO MITER BAND SAW MACHINE



Hydromechanic Band Tension



Hydraulic Vise







Material Infeed Table



Material Infeed Table



Inverter

CUTTING CAPACITY			
	0°	45°	60°
	15.75"	11.8"	10.6"
	15.75"	11.8"	10.6"
	15.75" x 19.7"	11.8" x 15.75"	10.6" x 15.75"

TECHNICAL SPECIFICATIONS							
Main Motor	Hydraulic Motor	Coolant Motor	Cutting Speed	Blade Size	Weight	Working Height	Dimensions
5.5 HP	1/2 HP	3/16 HP	82 - 295.2 fpm	15' 3" x 1.25" x 0.04"	2975 lbs	29.1"	55" x 87" x 47"



SEMI-AUTO MITER BAND SAW MACHINE

KMT 350 KDG

TECHNICAL SPECIFICATIONS

Main Motor	Hydraulic Motor	Coolant Motor	Cutting Speed	Blade Size	Weight	Working Height	Dimensions
5.5 HP	1/2 HP	3/16 HP	82 - 295 fpm	14' 3 1/4" x 1.25" x 0.04"	2755 lbs	29.1"	55." x 87" x 47"

CUTTING CAPACITY

	0°	45°	60°
	13.75"	9.9"	8.7"
	13.75"	9.9"	8.7"
	11.8" x 21.7"	9.9" x 15.75"	8.7" x 11.8"



Material Infeed Table



Material Infeed Table



Inverter



Hydromechanic Band Tension



Hydraulic Vise

KMT 300 KDG SEMI-AUTO MITER BAND SAW MACHINE



Hydromechanic Band Tension



Hydraulic Vise



Material Infeed Table



Material Infeed Table



Inverter

CUTTING CAPACITY			
	0°	45°	60°
	11.8"	11.8"	6.7"
	11.8"	11.8"	6.7"
	11.8" x 19.7"	11.8" x 11.8"	6.7" x 11.8"

TECHNICAL SPECIFICATIONS							
Main Motor	Hydraulic Motor	Coolant Motor	Cutting Speed	Blade Size	Weight	Working Height	Dimensions
3 HP	1/2 HP	3/16 HP	82 - 295 fpm	12' 7 1/2" x 1" x 0.035"	2060 lbs	29.1"	51" x 77" x 51"

SEMI-AUTO MITER BAND SAW MACHINE

KMT 220 KDG

SEMI-AUTO MITER



Hydromechanic Band Tension



Pneumatic Vise



Inverter



Material Infeed Table



CUTTING CAPACITY

	0°	45°	60°	-45°
	8.7"	7.9"	5.1"	7.9"
	8.7"	7.9"	4.7"	7.9"
	8.7" x 10.6"	7.9" x 7.9"	4.75" x 7.9"	7.9" x 7.9"

TECHNICAL SPECIFICATIONS

Main Motor	Hydraulic Motor	Coolant Motor	Cutting Speed	Blade Size	Weight	Working Height	Dimensions
2 HP	1/2 HP	3/16 HP	82 - 295 fpm	9' 10 ³ / ₃₂ " x 1" x 0.035"	1050 lbs	37.8"	31" x 77" x 67"

KMT 220 *craft*

MANUEL MITER BAND SAW MACHINE



Hydromechanic Band Tension



Fast Clamping Arm



Speed Adjustable Hydraulic Piston



One Way Miter Till 60°



Adjustable Length Setting Bar



Adjustable Tension Band Wheel

CUTTING CAPACITY

	0°	45°	60°
	0°	45°	60°
	8.7"	6.3"	3.75"
	8.7"	6.3"	3.75"
	8.7" x 9.9"	7.9" x 6.3"	7.9" x 3.75"

TECHNICAL SPECIFICATIONS

Main Motor	Coolant Motor	Cutting Speed	Blade Size	Weight	Working Height	Dimensions
1.5 HP	1/8 HP	82 - 292 fpm	8' 2 ⁷ / ₁₆ " x 1" x 0.035"	570 lbs	36"	25" x 61" x 55"

PLC CONTROLLED AUTO MITER BAND SAW MACHINE

KMT 350

ODG PLC



Hydromechanic Band Tension



Hydraulic Vise



Material Infeed Table



Material Infeed Table



Inverter - PLC Control Panel



AUTO MITTER

CUTTING CAPACITY

	0°	45°	60°
	13.75"	11"	7"
	13.75"	11"	7"
	12.6" x 18.1"	13.75" x 11"	7" x 7"

TECHNICAL SPECIFICATIONS

Main Motor	Hydraulic Motor	Coolant Motor	Cutting Speed	Blade Size	Weight	Working Height	Dimensions
5.5 HP	1/2 HP	3/16 HP	82 - 295 fpm	14' 3 1/4" x 1.25" x 0.04"	2975 lbs	29.1"	55" x 87" x 47"

KMT 300 **ODG** **PLC**

PLC CONTROLLED AUTO MITER BAND SAW MACHINE



Hydromechanic Band Tension



Hydraulic Vise



Inverter - PLC Control Panel



Material Infeed Table



Material Infeed Table

CUTTING CAPACITY

	0°	45°	60°
	0°	45°	60°
	11.8"	9.8"	3.9"
	11.8"	8.2"	3.9"
	11.8" x 13.75"	6.7" x 9.9"	3.9" x 3.9"

TECHNICAL SPECIFICATIONS

Main Motor	Hydraulic Motor	Coolant Motor	Cutting Speed	Blade Size	Weight	Working Height	Dimensions
3 HP	1/2 HP	3/16 HP	82 - 295 fpm	12' 7 1/2" x 1" x 0.035"	2115 lbs	29.1"	51" x 77" x 51"

AUTOMATIC MITER BAND SAW MACHINE

KMT 220 ODG

AUTO MITTER



Hydromechanic Band Tension





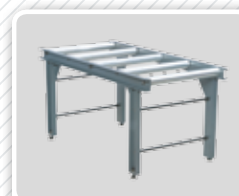

Hydraulic Vise



Material Infeed Table



Inverter

CUTTING CAPACITY		
	0°	45°
	8.7"	6.3"
	8.7"	6.3"
	7.9" x 8.7"	6.3" x 8.7"

TECHNICAL SPECIFICATIONS							
Main Motor	Hydraulic Motor	Coolant Motor	Cutting Speed	Blade Size	Weight	Working Height	Dimensions
2 HP	1/2 HP	3/16 HP	82 - 295 fpm	28' 3 1/2" x 1" x 0.035"	1345 lbs	29.9"	51" x 69" x 45"

KMT 800 KSA SEMI-AUTO DOUBLE COLUMN



TECHNICAL SPECIFICATIONS

Main Motor	Hydraulic Motor	Conveyor Motor	Coolant Motor	Cutting Speed	Blade Size	Weight	Working Height	Dimensions
10 HP	2 HP	1/4 HP	1/4 hp	59 - 246 fpm	28' 3 1/2" x 2.5" x 0.06"	11450 lbs	21.6"	83" x 164" x 91"

BAND SAW MACHINE



SEMI-AUTO STRAIGHT

CUTTING CAPACITY	
	0°
	31.5"
	31.5"
	31.5" x 39.4"



Sensitive Pressure - Inverter - Hydraulic Brake - Digital Control Panel



Chip Conveyor



Motorized Chip Brush



Out Of Square Sawing Detector (Opt.)



Front - Back Feeder Roller



Hydraulic Band Tension



Material Infeed Table

KMT 560 KSA

SEMI-AUTO DOUBLE COLUMN

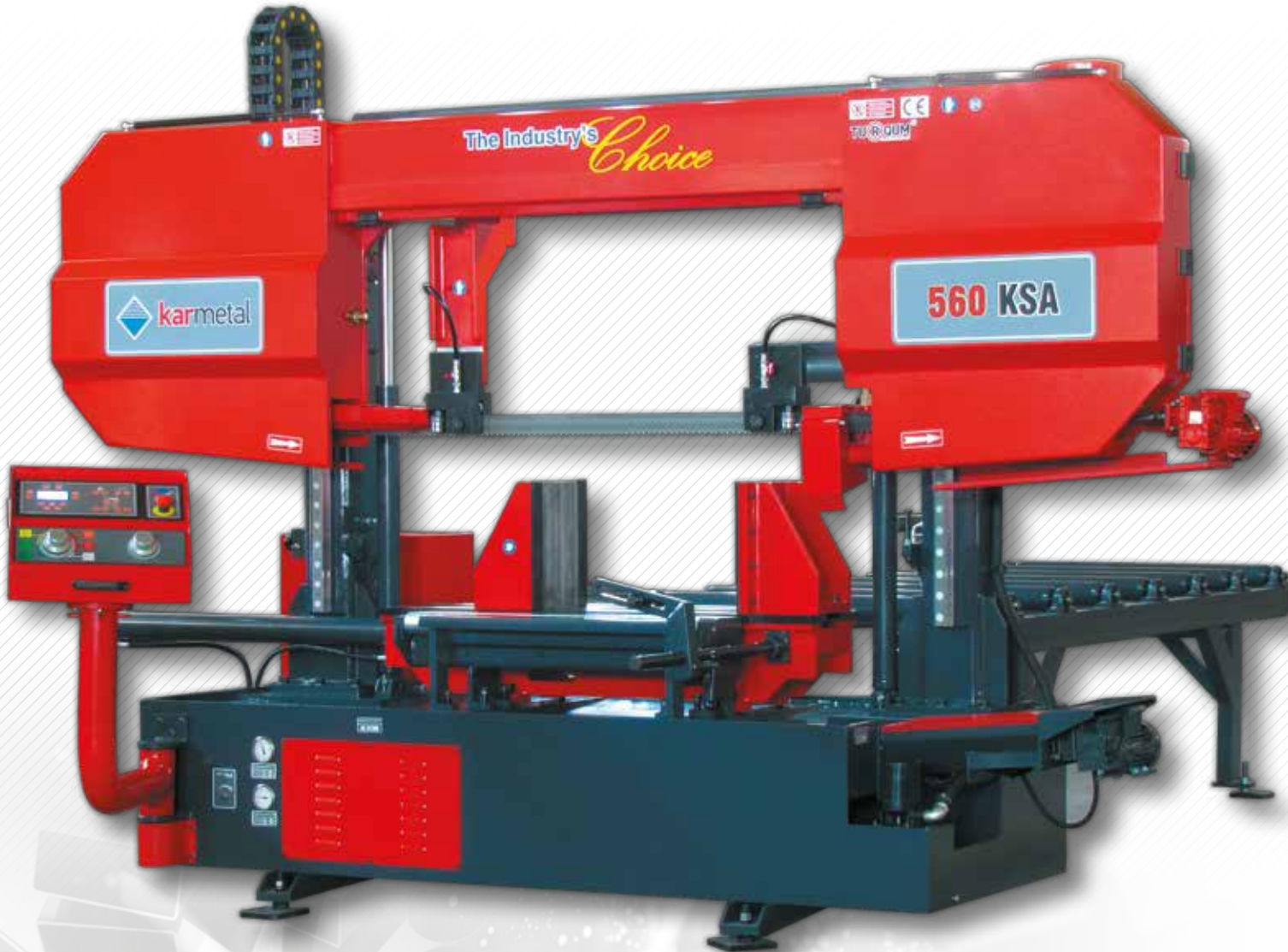

TECHNICAL SPECIFICATIONS

Main Motor	Hydraulic Motor	Conveyor Motor	Coolant Motor	Cutting Speed	Blade Size	Weight	Working Height	Dimensions
7.5 HP	2 HP	1/4 HP	1/4 hp	59 - 246 fpm	21' 7 1/16" x 2" x 0.06"	6060 lbs	28.75"	55" x 125" x 84"

BAND SAW MACHINE



Motorized Chip Brush



Hydraulic Band Tension



Chip Conveyor



Material Infeed Table



Sensitive Pressure - Inverter - Hydraulic Vise - Digital Control Panel



CUTTING CAPACITY	
	0°
	22"
	22"
	22" x 31.5"

SEMI-AUTO STRAIGHT

KMT 460 KSA

SEMI-AUTO DOUBLE COLUMN



TECHNICAL SPECIFICATIONS

Main Motor	Hydraulic Motor	Conveyor Motor	Coolant Motor	Cutting Speed	Blade Size	Weight	Working Height	Dimensions
5.5 HP	2 HP	1/4 HP	1/4 hp	59-246 fpm	17' 8 5/8" x 1.5" x 0.05"	4960 lbs	34.25"	71" x 110" x 173"

BAND SAW MACHINE

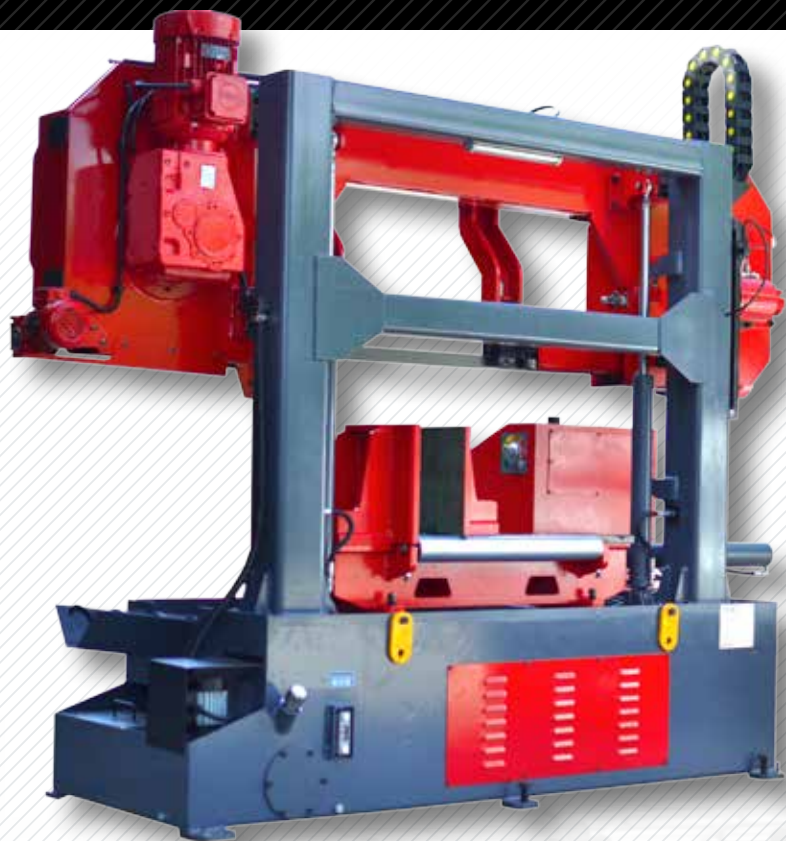

Motorized Chip Brush



Hydraulic Band Tension



Chip Conveyor



Material Infeed Table



Sensitive Pressure - Inverter - Hydraulic Vise - Digital Control Panel

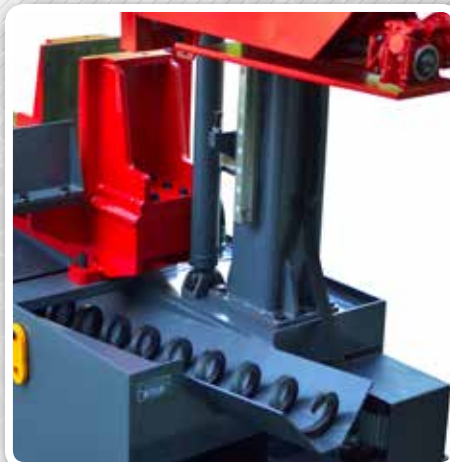

CUTTING CAPACITY	
	0°
	18.1"
	18.1"
	18.1" x 23.6"

SEMI-AUTO STRAIGHT

KMT 400 KSA SEMI-AUTO MITER BAND SAW MACHINE



Hydromechanic Band Tension



Hydraulic Vise



Inverter



Material Infeed Table

TECHNICAL SPECIFICATIONS								
Model	Main Motor	Hydraulic Motor	Coolant Motor	Cutting Speed	Blade Size	Weight	Working Height	Dimensions
400 KSA	5.5 HP	1/2 HP	1/8 HP	82 - 295 fpm	15' 3" x 1.25" x 0.04"	2975 lbs	29.5"	55" x 87" x 47"
350 KSA	5.5 HP	1/2 HP	1/8 HP	82 - 295 fpm	14' 11" x 1.25" x 0.04"	2190 lbs	29.5"	45" x 85" x 47"
300 KSA	3 HP	1/2 HP	1/8 HP	82 - 295 fpm	12' 7 1/2" x 1" x 0.03"	1980 lbs	29.5"	47" x 74" x 47"

KMT 350 KSA KMT 300 KSA

CUTTING CAPACITY

	400 KSA	350 KSA	300 KSA
∅	15.75"	13.75"	11.8"
▧	15.75"	13.75"	11.8"
▨	15.75" x 17.7"	13.75" x 17.7"	11.8" x 13.75"



SEMI-AUTO STRAIGHT

KMT 560 WOS

PLC CONTROLLED DOUBLE C



TECHNICAL SPECIFICATIONS

Main Motor	Hydraulic Motor	Conveyor Motor	Coolant Motor	Cutting Speed	Feeding Stroke	Blade Size	Weight	Working Height	Dimensions
7.5 HP	2 HP	1/4 HP	1/4 HP	72 - 328 fpm	31.5"	21' 7 1/16" x 2" x 0.06"	8375 lbs	28.75"	89" x 125" x 84"

COLUMN AUTO BAND SAW MACHINE

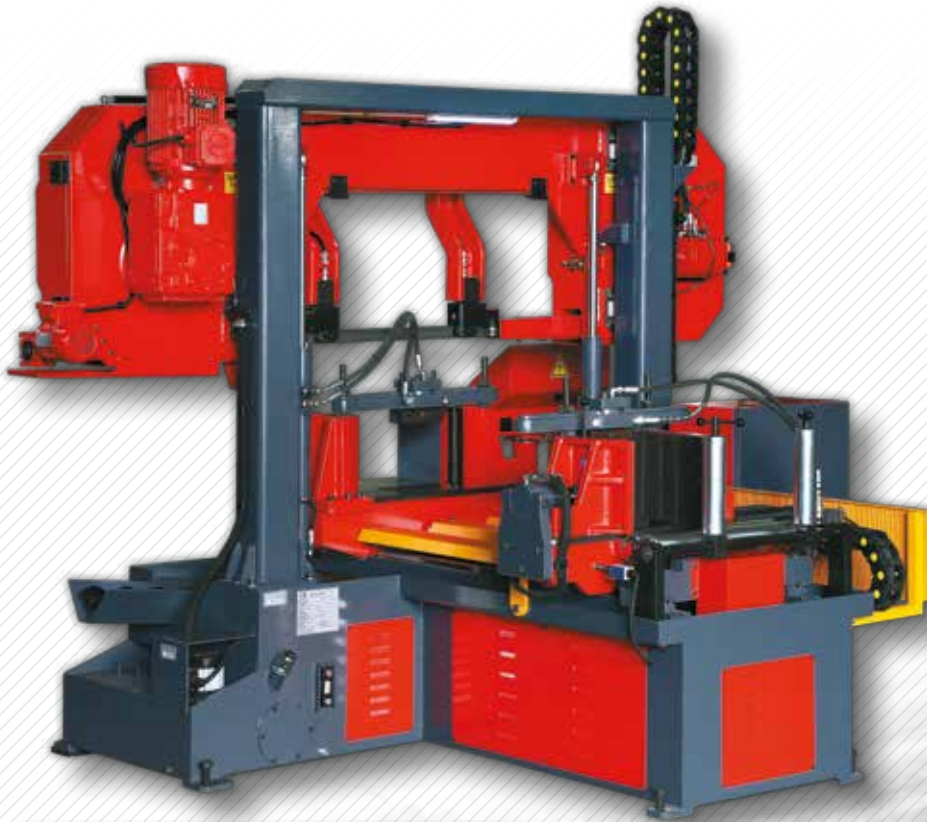

Chip Conveyor



Hydraulic Top Clamp



Hydraulic Band Tension



Material Infeed Table



Motorized Chip Brush



Sensitive Pressure - Inverter -Hydraulic Vise

CUTTING CAPACITY	
	0°
	22"
	22"
	22" x 27.5"
	15" x 27.5"

KMT 460 WOS M3





PLC CONTROLLED



TECHNICAL SPECIFICATIONS

Main Motor	Hydraulic Motor	Conveyor Motor	Coolant Motor	Cutting Speed	Feeding Stroke	Blade Size	Weight	Working Height	Dimensions
7.5 HP	2 HP	1/4 HP	1/4 HP	72 - 328 fpm	31.5"	17' 8 5/8" x 1.5" x 0.05"	5070 lbs	27.75"	83" x 102" x 81"

DOUBLE COLUMN AUTO BAND SAW MACHINE

CUTTING CAPACITY	
	0°
	19"
	19"
	19" x 21.6"
	11.4" x 15.75"

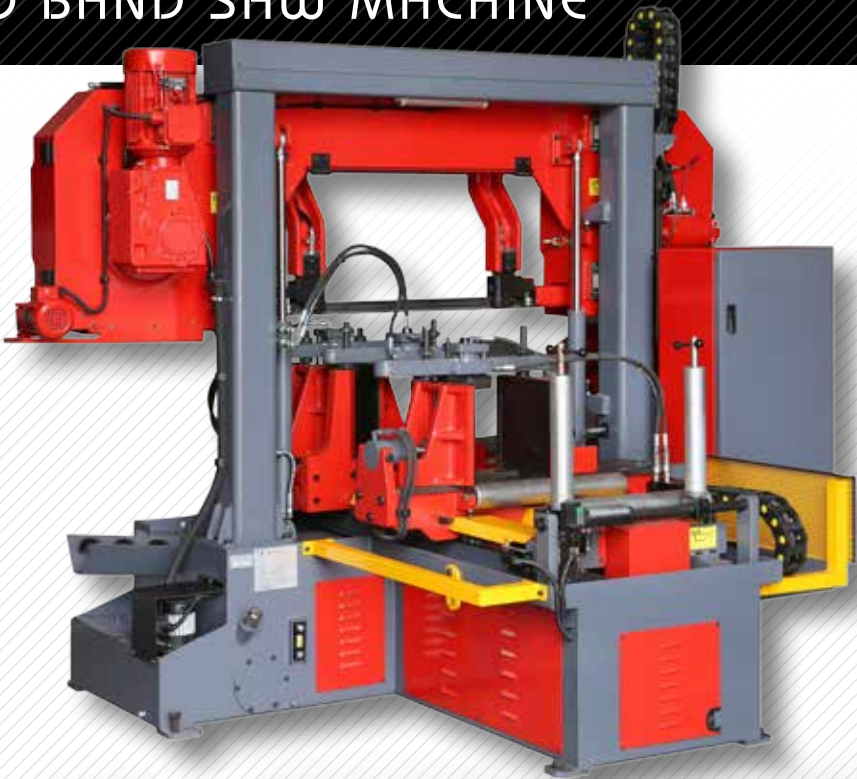

Sensitive Pressure - Inverter - Hydraulic Vise



Chip Conveyor



Hydraulic Top Clamp



Hydraulic Band Tension



Material Infeed Table



Motorized Chip Brush

BUNDLE CUTTING SERIES

KMT 460 WOS M2





PLC CONTROLLED



TECHNICAL SPECIFICATIONS

Main Motor	Hydraulic Motor	Conveyor Motor	Coolant Motor	Cutting Speed	Feeding Stroke	Blade Size	Weight	Working Height	Dimensions
7.5 HP	2 HP	1/4 HP	1/4 HP	72 - 328 fpm	31.5"	17' 8 5/8" x 1.5" x 0.05"	5070 lbs	27.75"	83" x 102" x 81"

DOUBLE COLUMN AUTO BAND SAW MACHINE

CUTTING CAPACITY	
	0°
	19"
	19"
	19" x 21.6"
	11.4" x 15.75"



Sensitive Pressure - Inverter - Hydraulic Vise



Chip Conveyor



Hydraulic Top Clamp



Hydraulic Band Tension



Material Infeed Table







Motorized Chip Brush

BUNDLE CUTTING SERIES

KMT 340 WOS

PLC CONTROLLED AUTO BAND

CUTTING CAPACITY	
	0°
	13.4"
	13.4"
	13.4" x 16.9"
	7.9" x 11.8"



TECHNICAL SPECIFICATIONS									
Main Motor	Hydraulic Motor	Conveyor Motor	Coolant Motor	Cutting Speed	Feeding Stroke	Blade Size	Weight	Working Height	Dimensions
5 HP	1/2 HP	1/4 HP	3/16 HP	72 - 328 fpm	23.6"	12' 10" x 1.33" x 0.04"	3970 lbs	27.5"	81 x 51 x 63 mm

SAW MACHINE



PLC Control Panel - Inverter



Motrized Chip Brush (Opt.)



Hydraulic Band Tension (Opt.)



Material Infeed Table



Chip Conveyor



Hydraulic Top Clamp (Opt.)



Sensitive Pressure

BUNDLE CUTTING SERIES

KMT 280 WOS





PLC CONTROLLED AUTO BAND



TECHNICAL SPECIFICATIONS

Main Motor	Hydraulic Motor	Conveyor Motor	Coolant Motor	Cutting Speed	Feeding Stroke	Blade Size	Weight	Working Height	Dimensions
3 HP	1/2 HP	1/4 HP	3/16 HP	72 - 328 fpm	23.6"	12' x 1" x 0.035"	2590 lbs	28.1"	65" x 738" x 49"

SAW MACHINE

CUTTING CAPACITY	
	0°
	11"
	11"
	11" x 11.8"
	5.5" x 11.8"



Hydraulic Top Clamp (Opt.)



Sensitive Pressure



Motorized Chip Brush (Opt.)



Hydraulic Band Tension (Opt.)



Material Infeed Table



Chip Conveyor



PLC Control Panel - Inverter

BUNDLE CUTTING SERIES

KMT 560 OSA PLC

PLC CONTROLLED



TECHNICAL SPECIFICATIONS

Main Motor	Hydraulic Motor	Conveyor Motor	Coolant Motor	Cutting Speed	Blade Size	Weight	Working Height	Dimensions
7.5 HP	2 HP	1/4 HP	1/4 HP	59 - 246 fpm	21' 7 1/16" x 2" x 0.06"	6170 lbs	28.75"	58" x 125" x 84"

AUTO BAND SAW MACHINE

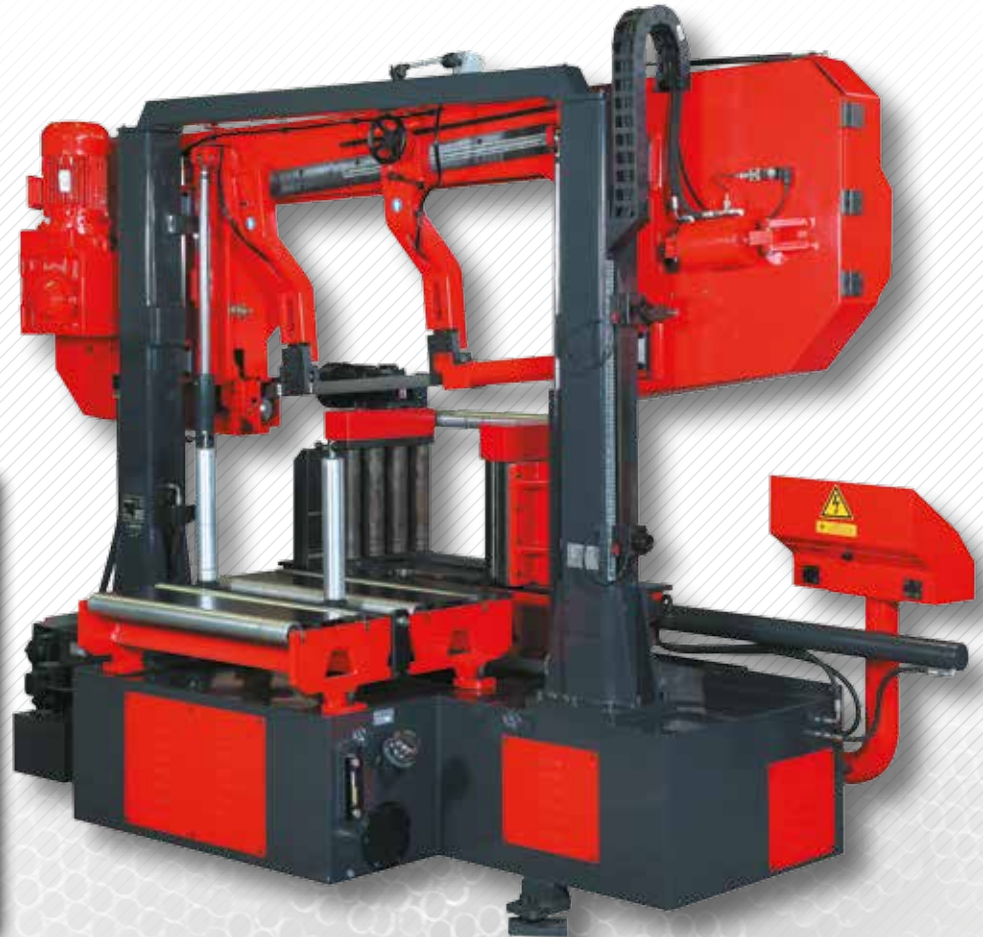

PLC Control Panel - Inverter - Hydraulic Vise - Sensitive Pressure



Hydraulic Band Tension



Material Infeed Table



Chip Conveyor



Motorized Chip Brush

CUTTING CAPACITY	
	0°
	22"
	22"
	22" x 25.6"

KMT 350 OSA PLC

PLC CONTROLLED AUTO BAND SAW MACHINE



Hydromechanic Band Tension



Hydraulic Vise



Material Infeed Table



Chip Conveyor



Inverter - PLC Control Panel

CUTTING CAPACITY

	0°
	13.75"
	13.75"
	12.6" x 16.9"

TECHNICAL SPECIFICATIONS



Main Motor	Hydraulic Motor	Coolant Motor	Cutting Speed	Blade Size	Weight	Working Height	Dimensions
5.5 HP	1/2 HP	3/16 HP	82 - 295 fpm	14' 3 1/4" x 1.25" x 0.04"	2190 lbs	28.75"	45" x 83" x 47"

AUTO BAND SAW MACHINE **KMT 350 OSA**

TECHNICAL SPECIFICATIONS

Main Motor	Hydraulic Motor	Coolant Motor	Cutting Speed	Blade Size	Weight	Working Height	Dimensions
5.5 HP	1/2 HP	3/16 HP	82 - 295 fpm	14' 3 1/4" x 1.25" x 0.04"	2190	28.75"	45" x 83" x 47"

CUTTING CAPACITY

	0°
	13.75"
	13.75"
	12.6" x 16.9"



Hydraulic Vise



Material Infeed Table



Hydromechanic Band Tension



Inverter - Digital Control Panel



KMT 300 OSA PLC

PLC CONTROLLED AUTO BAND SAW MACHINE



Hydromechanic Band Tension



Hydraulic Vise



Material Infeed Table



Chip Conveyor



Inverter - PLC Control Panel

CUTTING CAPACITY	
	0°
	11.8"
	11.8"
	11.8" x 15"

TECHNICAL SPECIFICATIONS

Main Motor	Hydraulic Motor	Coolant Motor	Cutting Speed	Blade Size	Weight	Working Height	Dimensions
3 HP	1/2 HP	3/16 HP	82 – 295 fpm	12' 7 1/2" x 1" x 0.035"	1980 lbs	28.75"	48" x 77" x 51"

AUTO BAND SAW MACHINE **KMT 300 OSA**



Hydromechanic Band Tension



Material Infeed Table



Hydraulic Vise



Inverter - Digital Control Panel

CUTTING CAPACITY	
	0°
	11.8"
	11.8"
	11.8" x 14.9"

TECHNICAL SPECIFICATIONS

Main Motor	Hydraulic Motor	Coolant Motor	Cutting Speed	Blade Size	Weight	Working Height	Dimensions
3 HP	1/2 HP	3/16 HP	82 - 295 fpm	12' 7 1/2" x 1" x 0.035"	900 kg	28.74"	48" x 77" x 51"

AUTO STRAIGHT

KMT 800 SDG

SEMI-AUTO COLUMN BAND SAW MACHINE
(For Plastic Alloyed Pipes Only)



TECHNICAL SPECIFICATIONS							CUTTING CAPACITY	
Main Motor	Hydraulic Motor	Cutting Speed	Blade Size	Weight	Working Height	Dimensions		
5.5 HP	1/2 HP	131.2 - 525 fpm	19' x 1.25" x 0.04"	5500 lbs	26.75"	205" x 102" x 134"	0°	31.5"
							30°	31.5"
							45°	27.5"

SEMI-AUTO COLUMN BAND SAW MACHINE (For Plastic Alloyed Pipes Only)

KMT 1400 SDG



TECHNICAL SPECIFICATIONS							CUTTING CAPACITY	
Main Motor	Hydraulic Motor	Cutting Speed	Blade Size	Weight	Working Height	Dimensions		
7.5 HP	3 HP	131 - 525 fpm	32" x 1.25" x 0.04"	10800	29.5"	161" x 157" x 222"	0°	55.1"
							30°	55.1"
							45°	55.1"

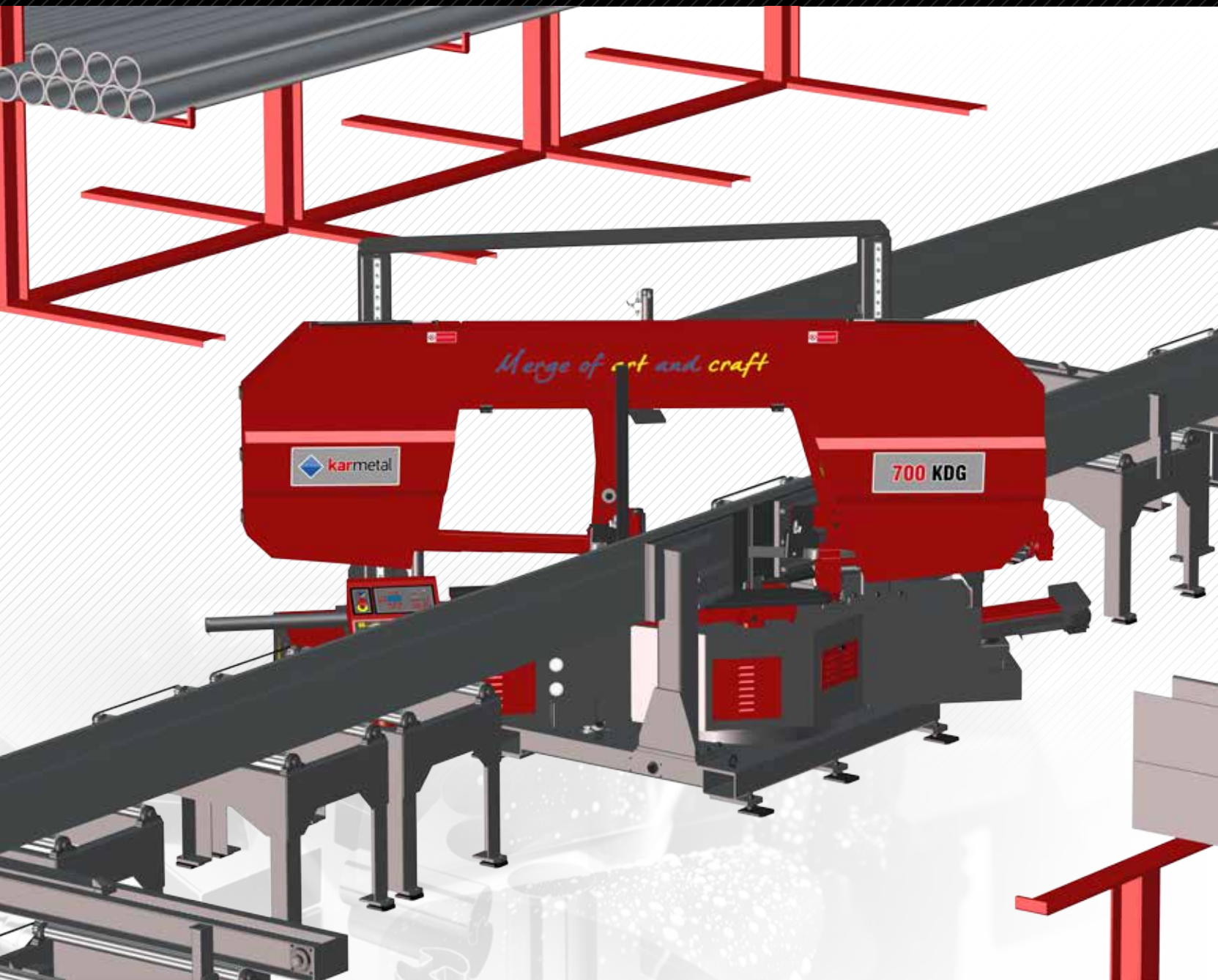

Industrial Solutions



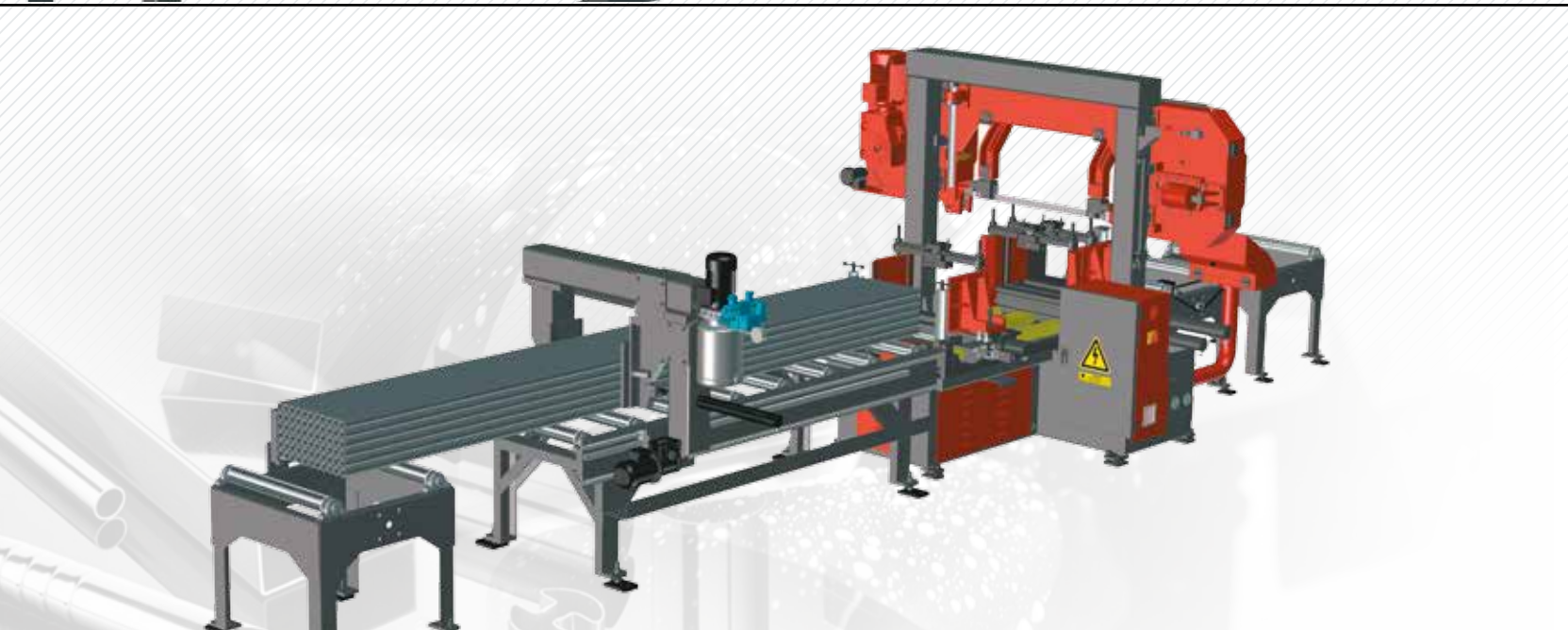
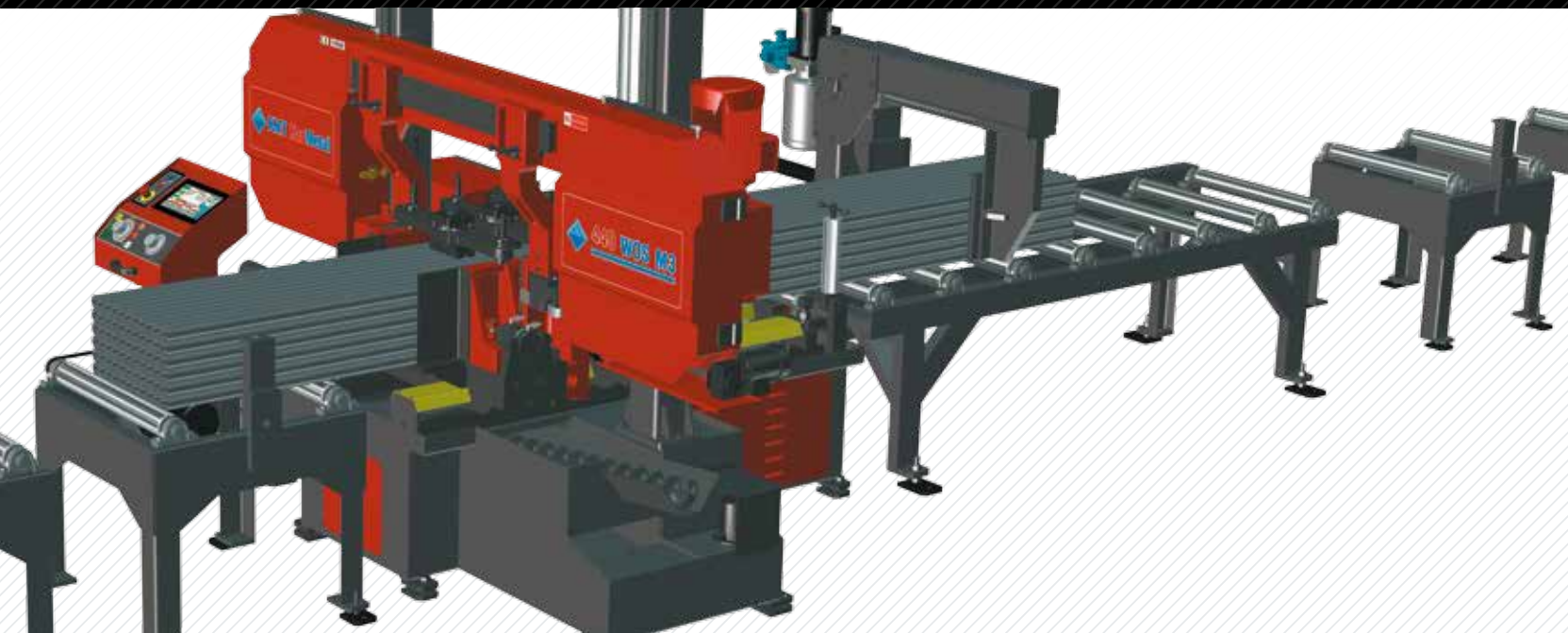

Special Solutions

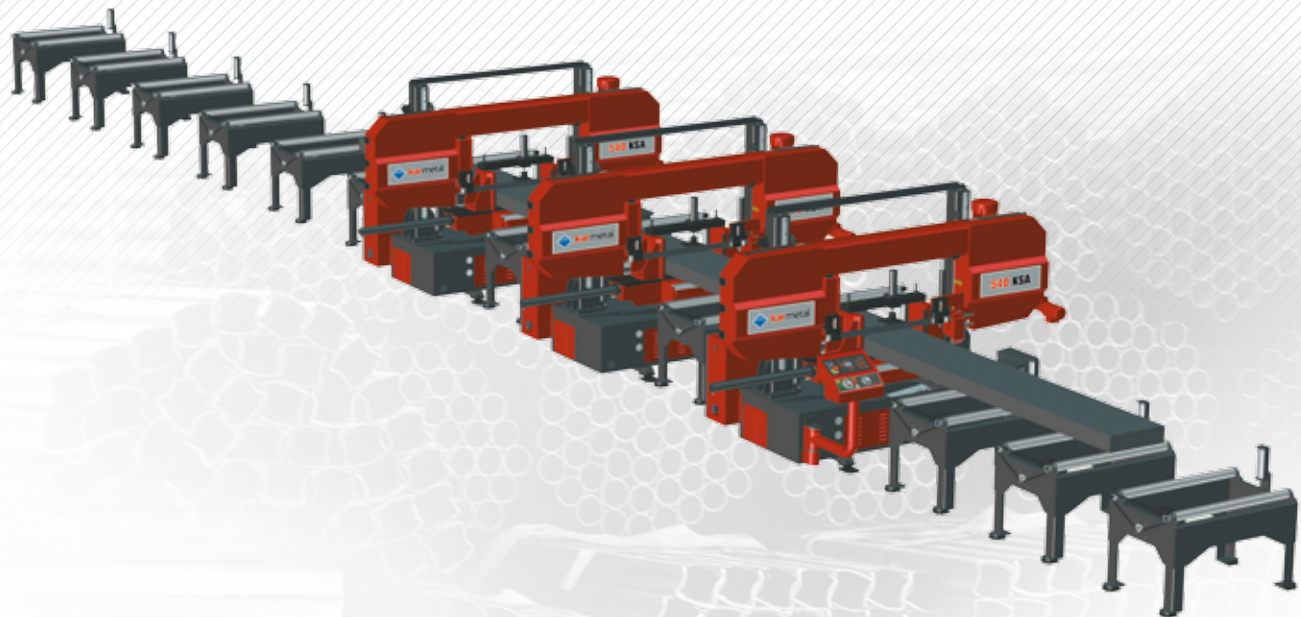
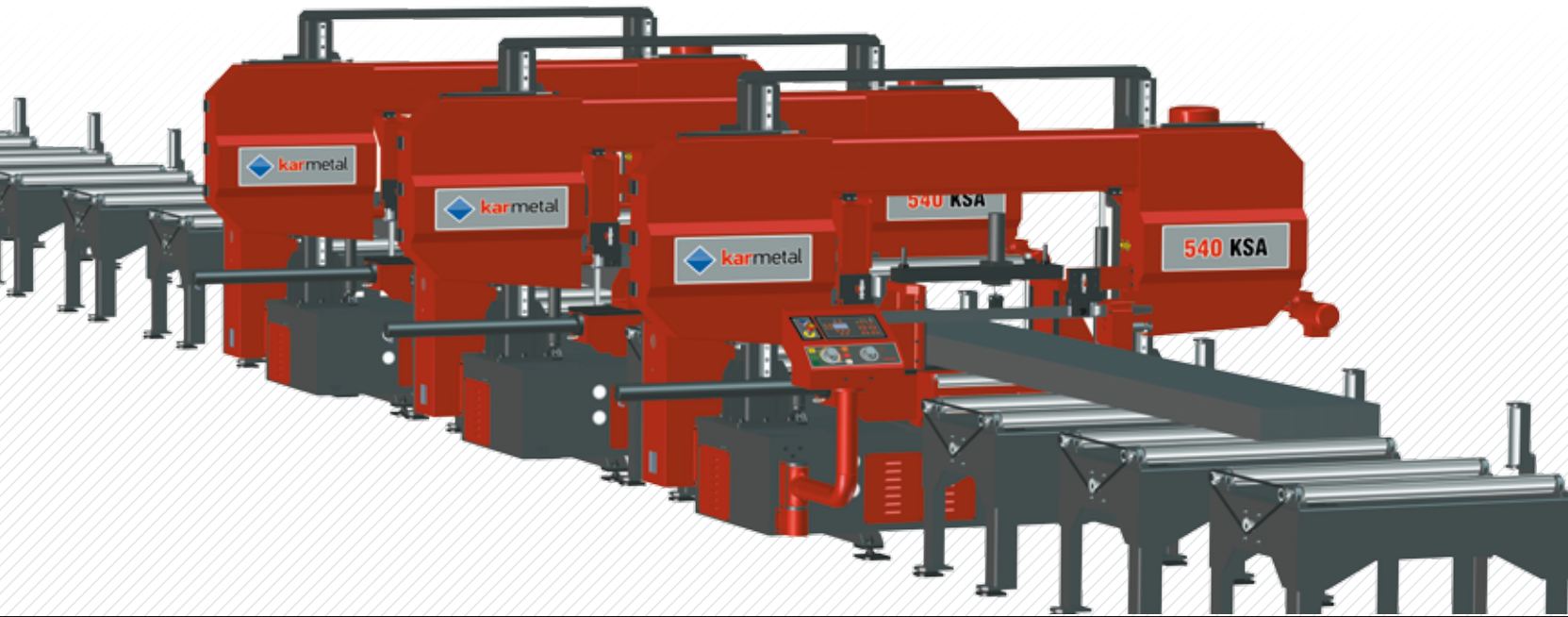

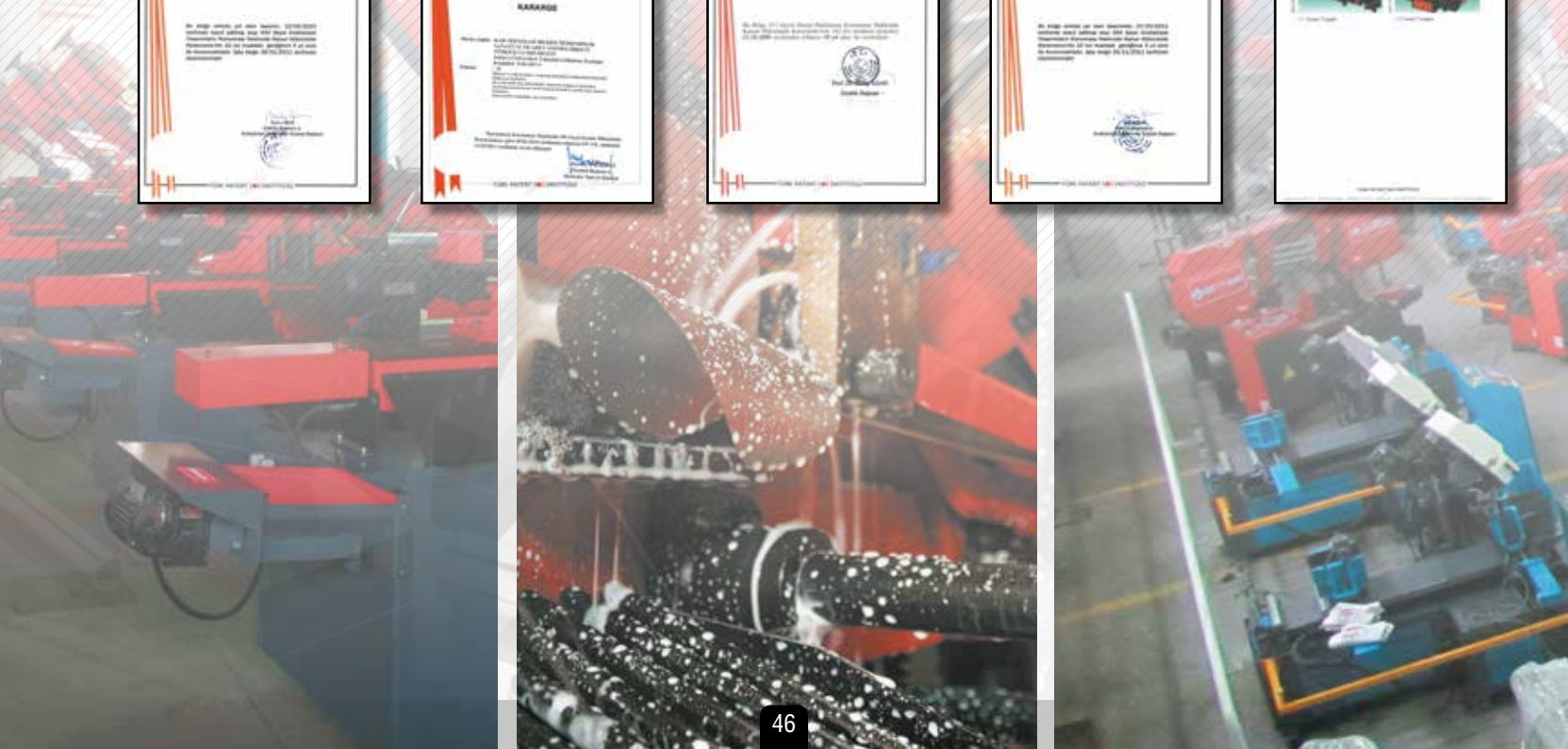
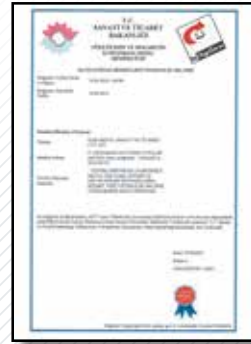

Certificates





karmetalusa
Merge of art and craft

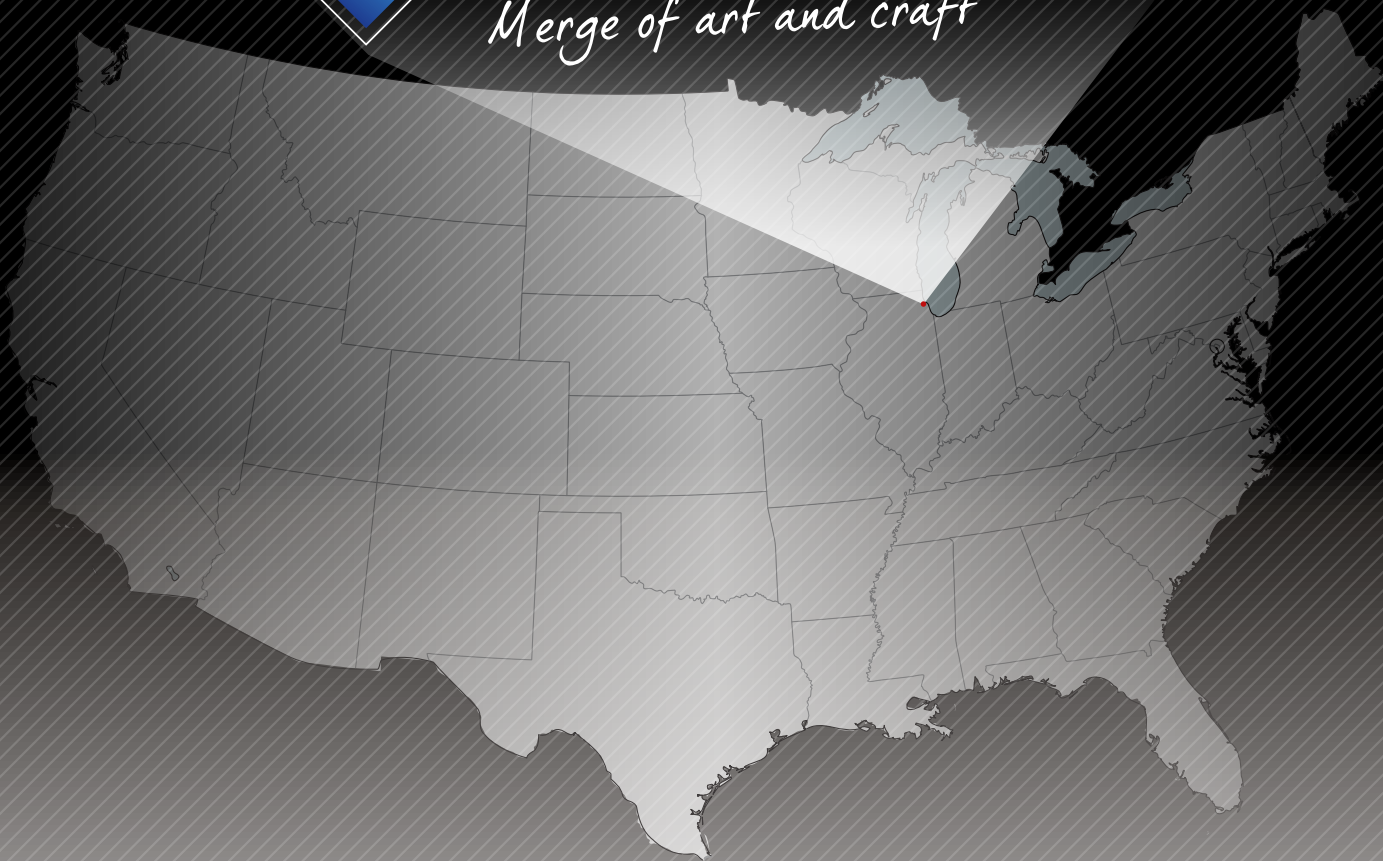

1084 Industrial Drive #1
Bensenville, IL 60106 USA
Office: +1 (630) 847-7775
www.karmetal.us
sales@karmetal.us